

# Equipment Cover

## X-Ray Cassette Covers

CODE	DESCRIPTION	CASE QTY	CASE DIMENSIONS
46-CAS2440D	X-Ray Cassette Cover Large Double Cuffed 24x40" (61x102cm)	100	TBD
46-CAS2440D-S	X-Ray Cassette Cover Large Double Cuffed 24x40" (61x102cm)	50	20x11x18" (52x29x47cm)

### Materials

- Clear Polyethylene (PE) Film

### Product Attributes

- Double cuff design
- Large size fits most cassettes

### Sterilization

**Sterile:** Sterilized by EO (ethylene oxide). Product is sterile unless the package has been damaged or opened.

**Non-Sterile:** If a product is delivered non-sterile and is ultimately for use in sterile environments, it is intended to be sterilized by the re-packager. This includes further packaging and sterilization according to the validated processes of the re-packager. These products are to be sterilized by ethylene oxide (EO). Other methods of sterilization have not been validated by Alleset.

### Shelf Life

**Sterile:** 5 years

**Non-Sterile:** Established at 5 years based upon sterile packaged product aging studies and normal warehouse storage conditions. After 5 years, the product should be performance tested to ensure compliance to specifications.

### Product Certifications/Standards

- CE certified as Class I, according to MDR 2017/745 Annex VIII, Rule 1

### Manufacturing Certifications/Registrations

- EN ISO 13485:2016
- Medical Device Single Audit Process Certified

### Storage

- General warehouse conditions

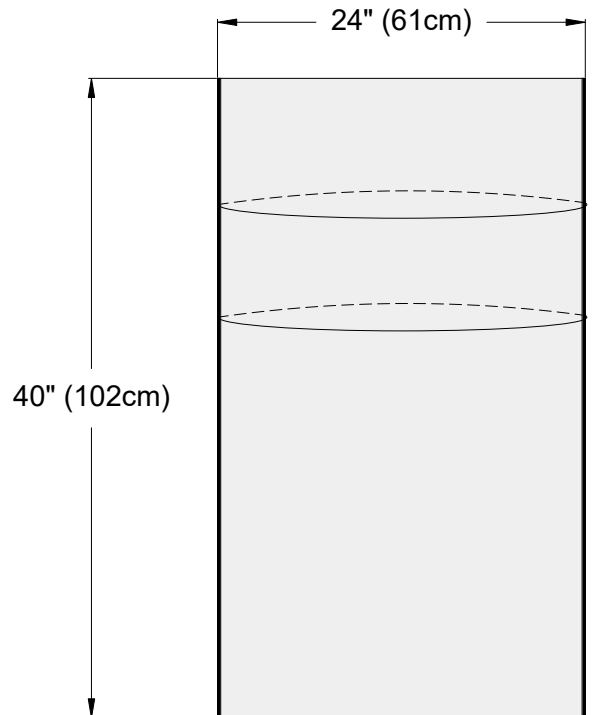

Alleset  
4142 Industry Way  
Flowery Branch, GA 30542,  
USA  
www.alleset.com  
SM-TDS-003 2024  
Country of Origin Abbreviations per ISO 3166-1, Alpha-2 Codes.



GRI Medical & Electronic Technology Co., LTD  
1805 Honggao Road,  
314031 Jiaxing, Zhejiang  
PEOPLE'S REPUBLIC OF CHINA  
www.alleset.com  
US FDA Establishment Registration #3004911384



Emergo Europe B.V.  
Westervoortsedijk 60,  
6827 AT Arnhem,  
The Netherlands  
www.emergobyul.com

