

# Patient Positioning

## Ulnar Nerve Protector

CODE	DESCRIPTION	CASE QTY	CASE DIMENSIONS
50-150201	Ulnar Nerve Protector, 15.5x6x2" (39x15x5cm)	36	20.5x18x19" (52x46x49cm)

### Materials

- Polyurethane Foam
- Hook and Loop

### Product Attributes

- Convoluted "egg crate" polyurethane foam
- Hook and loop straps

### Sterilization

Non-Sterile: This product is intended to be used non-sterile. If the repackager intends to sterilize this product, a validation must be conducted to demonstrate their sterilization process will meet all the ISO 11135 and EN 10993 requirements to demonstrate sterility and EO/ECH residual compliance. It must be done according to their validated sterilization process.

### Shelf Life

Non-Sterile: Established at 5 years based upon sterile packaged product aging studies and normal warehouse storage conditions. After 5 years, the product should be performance tested to ensure compliance to specifications.

### Product Certifications/Standards

- CE certified as Class I, according to MDR 2017/745 Annex VIII, Rule 1

### Manufacturing Certifications/Registrations

- EN ISO 13485:2016

### Storage

- General warehouse conditions

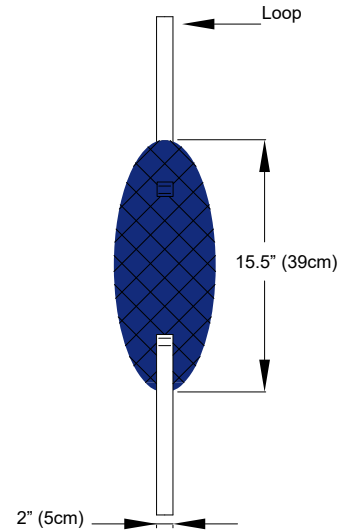

Alleset  
4142 Industry Way  
Flowery Branch, GA 30542,  
USA  
www.alleset.com  
SM-TDS-002 2022  
Country of Origin Abbreviations per ISO 3166-1, Alpha-2 Codes.



Global Resources International Tennessee Foam Inc,  
910 Callahan Dr #108,  
Knoxville, Tennessee,  
37912 UNITED STATES  
www.alleset.com  
US FDA Establishment Registration #3017728970



Alleset Limited B.V.  
Kingsfordweg 151,  
1043 GR Amsterdam,  
The Netherlands  
www.alleset.com

