

Surgical Drapes

Orthopedic

CODE	DESCRIPTION	CASE QTY	CASE DIMENSIONS
80-14122	Fluid Collection Pouch, 44x35" (112x89cm)	90	20x12x15" (50x30x37cm)
80-14122-S	Fluid Collection Pouch, 44x35" (112x89cm)	60	20x12x23" (50x30x58cm)

Materials

- Clear Polyethylene (PE) Film

Product Attributes

- X-Large pleated fluid collection pouch
- Suction port

Sterilization

Sterile: Sterilized by EO (ethylene oxide). Product is sterile unless the package has been damaged or opened.
Non-Sterile: If a product is delivered non-sterile and is ultimately for use in sterile environments, it is intended to be sterilized by the re-packer. This includes further packaging and sterilization according to the validated processes of the re-packer. These products are to be sterilized by ethylene oxide (EO). Other methods of sterilization have not been validated by Alleset.

Shelf Life

Sterile: 5 years
Non-Sterile: Established at 5 years based upon sterile packaged product aging studies and normal warehouse storage conditions. After 5 years, the product should be performance tested to ensure compliance to specifications.

Product Certifications/Standards

- CE certified as Class I, according to MDR 2017/745 Annex VIII, Rule 1

Manufacturing Certifications/Registrations

- EN ISO 13485:2016
- Medical Device Single Audit Process Certified

Storage

- General warehouse conditions

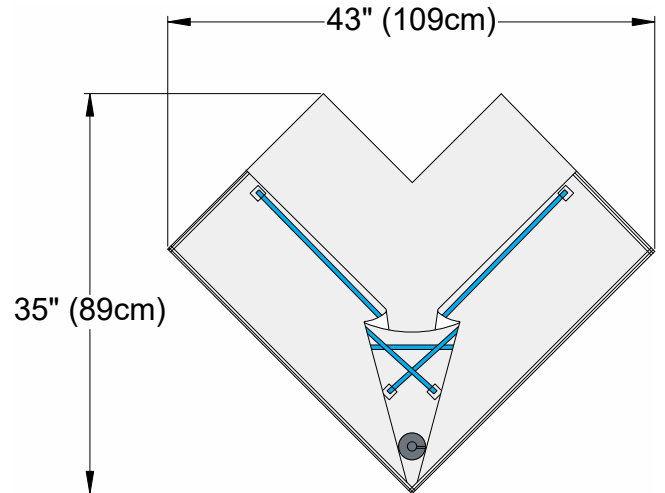

Alleset
 4142 Industry Way
 Flowery Branch, GA 30542,
 USA
www.alleset.com
 SM-TDS-003 2023
 Country of Origin Abbreviations per ISO 3166-1, Alpha-2 Codes.

GRI Medical & Electronic Technology Co., LTD
 1805 Honggao Road,
 314031 Jiaxing, Zhejiang
 PEOPLE'S REPUBLIC OF CHINA
www.alleset.com
 US FDA Establishment Registration #3004911384

Emergo Europe B.V.
 Westervoortsedijk 60,
 6827 AT Arnhem,
 The Netherlands
www.emergobyul.com