

Surgical Drapes

Obstetrics/Gynecology

CODE	DESCRIPTION	CASE QTY	CASE DIMENSIONS
N 80-14106G	Under Buttocks Drape w/ Fluid Collection Pouch, 40x44" (102x112cm)	42	17x11x16" (43x29x40cm)
S 80-14106G-S	Under Buttocks Drape w/ Fluid Collection Pouch, 40x44" (102x112cm)	14	20x13x18" (51x33x46cm)

Materials

- Blue Polyethylene (PE) Film
- HydraGuard® Absorbent Reinforcement
- Fluid Collection Pouch, Clear Polyethylene (PE) Film

Product Attributes

- Absorbent Reinforcement material for fluid management
- Fluid Collection pouch with graduated markings and suction port

Sterilization

Sterile: Sterilized by EO (ethylene oxide). Product is sterile unless the package has been damaged or opened.
Non-Sterile: If a product is delivered non-sterile and is ultimately for use in sterile environments, it is intended to be sterilized by the re-packer. This includes further packaging and sterilization according to the validated processes of the re-packer. These products are to be sterilized by ethylene oxide (EO). Other methods of sterilization have not been validated by Alleset.

Shelf Life

Sterile: 5 years
Non-Sterile: Established at 5 years based upon sterile packaged product aging studies and normal warehouse storage conditions. After 5 years, the product should be performance tested to ensure compliance to specifications.

Product Certifications/Standards

- Sterile: CE certified as Class I, according to MDD93/42/EEC Annex IX, Rule 4
- Non-Sterile: CE certified as Class I, according to MDR 2017/745 Annex VIII, Rule 1

Manufacturing Certifications/Registrations

- EN ISO 13485:2016
- Medical Device Single Audit Process Certified

Storage

- General warehouse conditions

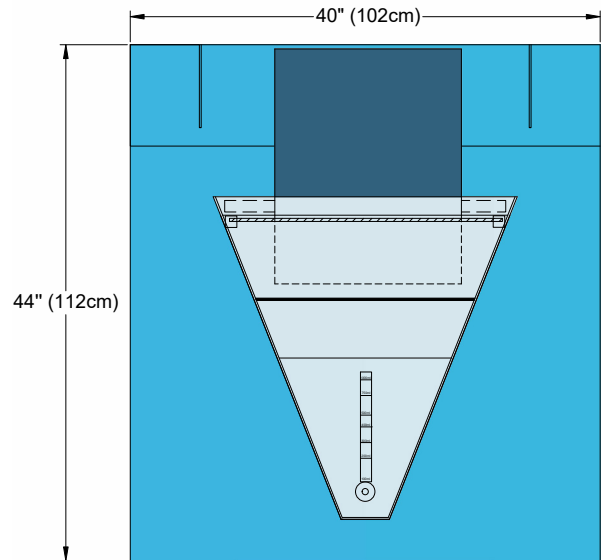

Alleset
 4142 Industry Way
 Flowery Branch, GA 30542,
 USA
www.alleset.com
 SM-TDS-002 2022
 Country of Origin Abbreviations per ISO 3166-1, Alpha-2 Codes.

GRI Medical & Electronic Technology Co., LTD
 1805 Honggao Road,
 314031 Jiaxing, Zhejiang
 PEOPLE'S REPUBLIC OF CHINA
www.alleset.com
 US FDA Establishment Registration #3004911384

EC REP Emergo Europe B.V.
 Prinsessegracht 20
 2514 AP The Hague
 The Netherlands
www.emergobyul.com

