

Surgical Drape

Lithotomy/Urology

CODE	DESCRIPTION	CASE QTY	CASE DIMENSIONS
80-11101G	Lithotomy Drape, w/ Attached Leggings, 87x100" (221x254cm)	20	20x16x14" (52x32x36cm)
80-11101G-S	Lithotomy Drape, w/ Attached Leggings, 87x100" (221x254cm)	22	21x14x18" (54x35x46cm)

Materials

- Multilayered SMS Material with Antistatic Properties and Alcohol Repellency
- HydraGuard® Absorbent Reinforcement

Product Attributes

- Perineal fenestration
- Attached leggings
- Absorbent reinforcement material for fluid management
- Tube holders

Sterilization

Sterile: Sterilized by EO (ethylene oxide). Product is sterile unless the package has been damaged or opened.
Non-Sterile: If a product is delivered non-sterile and is ultimately for use in sterile environments, it is intended to be sterilized by the re-packer. This includes further packaging and sterilization according to the validated processes of the re-packer. These products are to be sterilized by ethylene oxide (EO). Other methods of sterilization have not been validated by Alleset.

Shelf Life

Sterile: 5 years
Non-Sterile: Established at 5 years based upon sterile packaged product aging studies and normal warehouse storage conditions. After 5 years, the product should be performance tested to ensure compliance to specifications.

Product Certifications/Standards

- CE certified as Class I, according to MDR 2017/745 Annex VIII, Rule 1

Manufacturing Certifications/Registrations

- EN ISO 13485:2016
- Medical Device Single Audit Process Certified

Storage

- General warehouse conditions

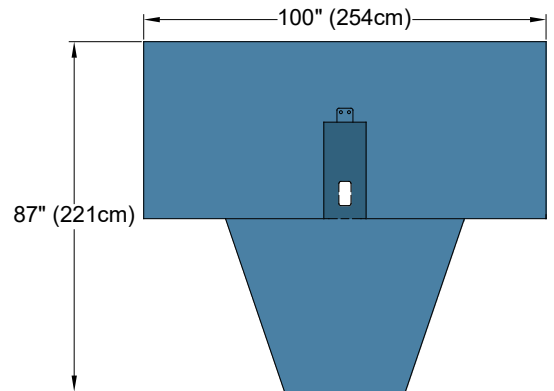

Alleset
 4142 Industry Way
 Flowery Branch, GA 30542,
 USA
www.alleset.com
 SM-TDS-003 2023

Country of Origin Abbreviations per ISO 3166-1, Alpha-2 Codes.

THINK.MAKE.PROTECT.



GRI Medical & Electronic Technology Co., LTD
 1805 Honggao Road,
 314031 Jiaxing, Zhejiang
 PEOPLE'S REPUBLIC OF CHINA
www.alleset.com
 US FDA Establishment Registration #3004911384



Emergo Europe B.V.
 Westervoortsedijk 60,
 6827 AT Arnhem,
 The Netherlands.
www.emergobyul.com

A GRI COMPANY

