

Patient Positioning

Foot, Heel and Elbow Protectors

CODE	DESCRIPTION	CASE QTY	CASE DIMENSIONS
50-150204	Foot Protector, 8.87x14" (22.5x35.5cm)	36 pair	24x24x18" (61x61x46cm)
50-150205	Heel/Elbow Protector, 9.25x19" (23.5x48.3cm)	36 pair	24x24x18" (61x61x46cm)

Materials

- Polyurethane Foam
- Hook and Loop Closure

Product Attributes

- Convoluted "egg crate" polyurethane foam

Sterilization

Non-Sterile: This product is intended to be used non-sterile. If the repackager intends to sterilize this product, a validation must be conducted to demonstrate their sterilization process will meet all the ISO 11135 and EN 10993 requirements to demonstrate sterility and EO/ECH residual compliance. It must be done according to their validated sterilization process.

Shelf Life

Non-Sterile: Established at 5 years based upon sterile packaged product aging studies and normal warehouse storage conditions. After 5 years, the product should be performance tested to ensure compliance to specifications.

Product Certifications/Standards

- CE certified as Class I, according to MDR 2017/745 Annex VIII, Rule 1

Manufacturing Certifications/Registrations

- EN ISO 13485:2016

Storage

- General warehouse conditions

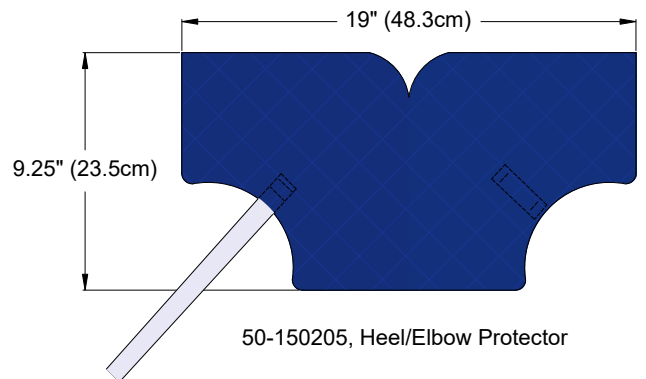
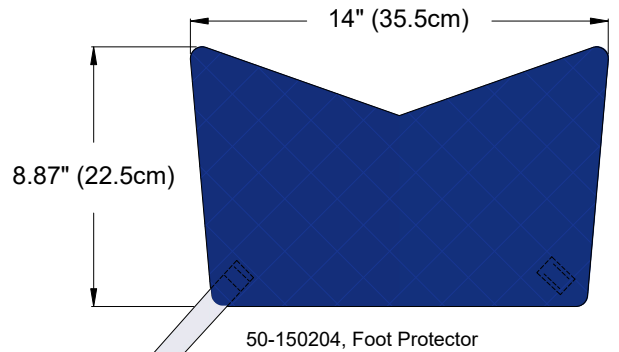

Alleset
4142 Industry Way
Flowery Branch, GA 30542,
USA
www.alleset.com
SM-TDS-002 2022
Country of Origin Abbreviations per ISO 3166-1, Alpha-2 Codes.



Global Resources International Tennessee Foam Inc,
910 Callahan Dr #108,
Knoxville, Tennessee,
37912 UNITED STATES
www.alleset.com
US FDA Establishment Registration #3017728970



Alleset Limited B.V.
Kingsfordweg 151,
1043 GR Amsterdam,
The Netherlands
www.alleset.com

