

Surgical Accessories

Drape Clip

CODE	DESCRIPTION	CASE QTY	CASE DIMENSIONS
25-0900	Drape Clip, 2x3" (6x7.6cm)	32	10.5x10.5x6" (26.5x26.5x14.5cm)

Materials

- Nylon
- Rivet and Spring: Stainless Steel

Product Attributes

- Reusable upto 20 uses
- 20 convex notches for tracking uses
- Large gripping surface

Sterilization

Non-Sterile: If a product is delivered non-sterile and is ultimately for use in sterile environments, it is intended to be sterilized using steam sterilization. This includes further packaging and sterilization according to the validated processes of the re-packager. Follow the sterilizer manufacturer's recommended time and temperature guidelines and hospital procedures for sterilization of this device. Other methods of sterilization have not been validated by Alleset.

Shelf Life

Non-Sterile: Established at 5 years based upon sterile packaged product aging studies and normal warehouse storage conditions. After 5 years, the product should be performance tested to ensure compliance to specifications.

Product Certifications/Standards

- CE certified as Class I, according to MDR 2017/745 Annex VIII, Rule 1

Manufacturing Certifications/Registrations

- EN ISO 13485:2016
- Medical Device Single Audit Process Certified

Storage

- General warehouse conditions

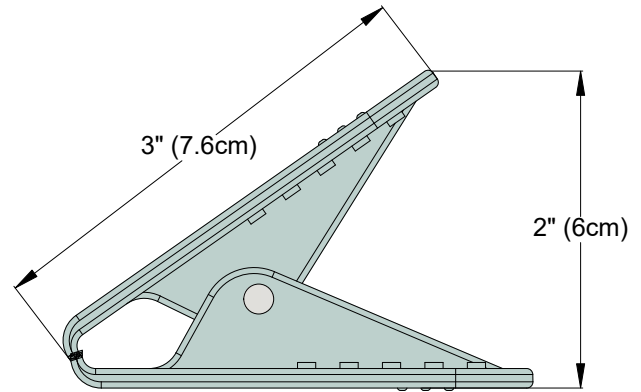

Alleset
4142 Industry Way
Flowery Branch, GA 30542,
USA
www.alleset.com
SM-TDS-003 2023

Country of Origin Abbreviations per ISO 3166-1, Alpha-2 Codes.

THINK.MAKE.PROTECT.



GRI Medical & Electronic Technology Co., LTD
1805 Honggao Road,
314031 Jiaxing, Zhejiang
PEOPLE'S REPUBLIC OF CHINA
www.alleset.com
US FDA Establishment Registration #3004911384

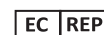

Emergo Europe B.V.
Westervoortsedijk 60,
6827 AT Arnhem,
The Netherlands
www.emergobyul.com

A GRI COMPANY

