

Equipment Covers

ECO² Basin Liners

	CODE	DESCRIPTION	CASE QTY	CASE DIMENSIONS
(N)	E80-13506	ECO ² Ring Basin Liner/Basin Stand Cover, Single, 52x52" (132x132cm)	50	20x13x16" (51x33x41cm)
(S)	E80-13506-S	ECO ² Ring Basin Liner/Basin Stand Cover, Single, 52x52" (132x132cm)	30	20x13x16" (51x33x41cm)
(N)	E80-13507	ECO ² Ring Basin Liner/Basin Stand Cover, Single, Flat, 52x52" (132x132cm)	30	19x19x8" (51x33x41cm)
(S)	E80-13509-S	ECO ² Ring Basin Liner/Basin Stand Cover, Double, 52x69" (132x176cm)	30	21x19x14" (52x45x39cm)
(N)	E80-13509	ECO ² Ring Basin Liner/Basin Stand Cover, Double, 52x69" (132x176cm)	50	21x19x14" (52x45x39cm)

Materials

- Bi-Color Film
- ECO² Blue Polyethylene (PE) Film

Product Attributes

- Certain components of this product incorporate ECO² sustainable materials which enhance product biodegradability
- Available in single or double basin configuration
- Product design reduces plastic resin requirements, sterile packaging and storage space versus traditional disposable ring basins
- 6000cc volume

Sterilization

Sterile: Sterilized by EO (ethylene oxide). Product is sterile unless the package has been damaged or opened.
Non-Sterile: If a product is delivered non-sterile and is ultimately for use in sterile environments, it is intended to be sterilized by the re-packer. This includes further packaging and sterilization according to the validated processes of the re-packer. These products are to be sterilized by ethylene oxide (EO). Other methods of sterilization have not been validated by Alleset.

Shelf Life

Sterile: 5 year
Non-Sterile: Established at 5 year based upon sterile packaged product aging studies and normal warehouse storage conditions. After 5 year, the product should be performance tested to ensure compliance to specifications.

Product Certifications/Standards

- Sterile: CE certified as Class I, according to MDD93/42/EEC Annex IX, Rule 4
- Non-Sterile: CE certified as Class I, according to MDR 2017/745 Annex VIII, Rule 1
- ASTM D5511-12 Standard Test Method for Determining Anaerobic Biodegradation of Plastics Materials Under High-Solids Anaerobic Digestion Conditions

Manufacturing Certifications/Registrations

- EN ISO 13485:2016
- Medical Device Single Audit Process Certified

Storage

- General warehouse conditions

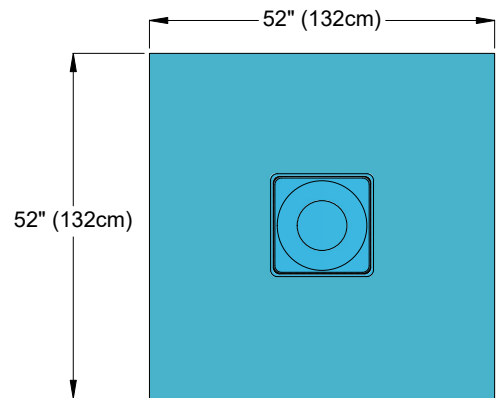

E80-13506, E80-13506-S, E80-13507

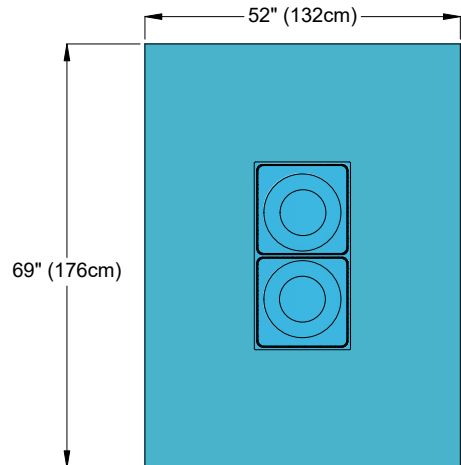

E80-13509, E80-13509-S



Alleset
 4142 Industry Way
 Flowery Branch, GA 30542,
 USA
www.alleset.com
 SM-TDS-003 2023
 Country of Origin Abbreviations per ISO 3166-1, Alpha-2 Codes.

GRI Medical & Electronic Technology Co., LTD
 1805 Honggao Road,
 314031 Jiaxing, Zhejiang
 PEOPLE'S REPUBLIC OF CHINA
www.alleset.com
 US FDA Establishment Registration #3004911384

EC REP Emergo Europe B.V.
 Westervoortsedijk 60,
 6827 AT Arnhem,
 The Netherlands
www.emergobyul.com

