

# Surgical Sharps Safety

## Scalpel Holder

	CODE	DESCRIPTION	CASE QTY	CASE DIMENSIONS
	30-0003	Scalpel Holder, 20x43" (52x110cm)	200	23x18x10" (58x46x25cm)
	30-0003-S	Scalpel Holder, 20x43" (52x110cm)	120	23x18x10" (58x46x25cm)

### Materials

- Polystyrene (PS)

### Product Attributes

- Accomodates upto 3 scalpels
- Adhesive backing

### Sterilization

**Sterile:** Sterilized by EO (ethylene oxide). Product is sterile unless the package has been damaged or opened.  
**Non-Sterile:** If a product is delivered non-sterile and is ultimately for use in sterile environments, it is intended to be sterilized by the re-packager. This includes further packaging and sterilization according to the validated processes of the re-packager. These products are to be sterilized by ethylene oxide (EO). Other methods of sterilization have not been validated by Alleset.

### Shelf Life

**Sterile:** 5 years  
**Non-Sterile:** Established at 5 years based upon sterile packaged product aging studies and normal warehouse storage conditions. After 5 years, the product should be performance tested to ensure compliance to specifications.

### Product Certifications/Standards

- CE certified as Class I, according to MDR 2017/745 Annex VIII, Rule 1

### Manufacturing Certifications/ Registrations

- EN ISO 13485:2016

### Storage

- General warehouse conditions

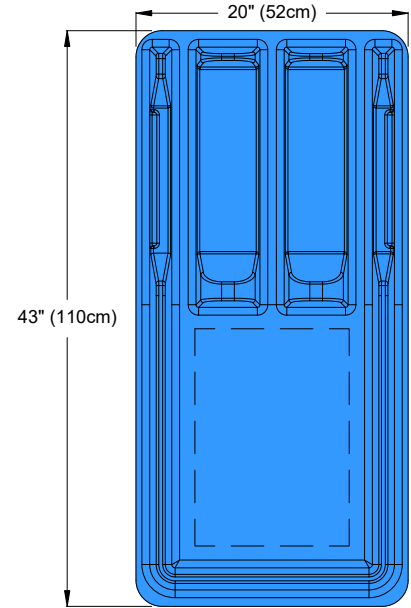

Alleset  
 4142 Industry Way  
 Flowery Branch, GA 30542,  
 USA  
[www.alleset.com](http://www.alleset.com)  
 SM-TDS-002 2024  
 Country of Origin Abbreviations per ISO 3166-1, Alpha-2 Codes.



GRI Medical & Electronic Technology Co., LTD  
 1805 Honggao Road,  
 314031 Jiaxing, Zhejiang  
 PEOPLE'S REPUBLIC OF CHINA  
[www.alleset.com](http://www.alleset.com)  
 US FDA Establishment Registration #3004911384



Emergo Europe B.V.  
 Westervoortsedijk 60,  
 6827 AT Arnhem,  
 The Netherlands  
[www.emergobyul.com](http://www.emergobyul.com)

