

Basins and Trays

ECO² Placenta Basin

CODE	DESCRIPTION	CASE QTY	CASE DIMENSIONS
E15-3000	ECO ² Placenta Basin, 3000ml	100	20x13x14" (51x34x35cm)
E15-9300	ECO ² Placenta Basin Lid, 3000ml	100	20x14x14" (52x35.5x35cm)

Materials

- ECO² Polypropylene

Product Attributes

- Certain components of this product incorporate ECO² sustainable materials which enhance product biodegradability
- Graduated in ml, cc and oz
- Optional lid available

Sterilization

Non-Sterile: If a product is delivered non-sterile and is ultimately for use in sterile environments, it is intended to be sterilized by the re-packer. This includes further packaging and sterilization according to the validated processes of the re-packer. These products are to be sterilized by ethylene oxide (EO). Other methods of sterilization have not been validated by Alleset.

Shelf Life

Non-Sterile: Established at 5 years based upon sterile packaged product aging studies and normal warehouse storage conditions. After 5 years, the product should be performance tested to ensure compliance to specifications.

Product Certifications

- CE certified as Class I, according to MDR 2017/745 Annex VIII, Rule 2
- ASTM D5511-12 Standard Test Method for Determining Anaerobic Biodegradation of Plastics Materials Under High-Solids Anaerobic Digestion Conditions

Manufacturing Certifications/Registrations

- EN ISO 13485:2016
- Medical Device Single Audit Process Certified

Storage

- General warehouse conditions

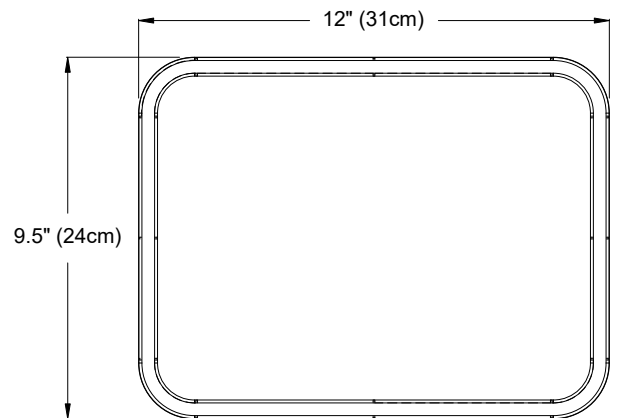
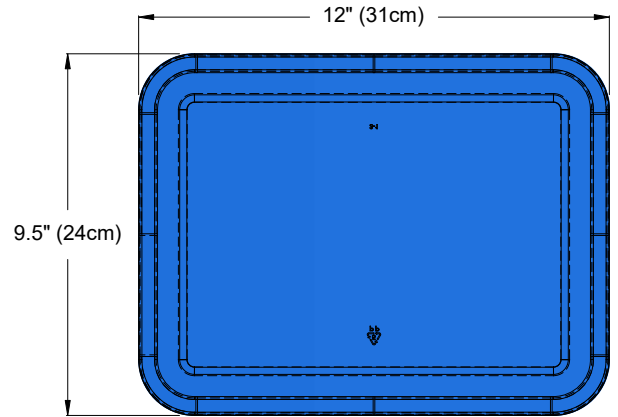

Alleset
4142 Industry Way
Flowery Branch, GA 30542,
USA
www.alleset.com
SM-TDS-003 2023
Country of Origin Abbreviations per ISO 3166-1, Alpha-2 Codes.



GRI Medical & Electronic Technology Co., LTD
1805 Honggao Road,
314031 Jiaxing, Zhejiang
PEOPLE'S REPUBLIC OF CHINA
www.alleset.com
US FDA Establishment Registration #3004911384



Emergo Europe B.V.
Westervoortsedijk 60,
6827 AT Arnhem,
The Netherlands
www.emergobyul.com

