

Basins and Trays

Guidewire Basins

CODE	DESCRIPTION	CASE QTY	CASE DIMENSIONS
15-GW2000CT	Basin, Guidewire, 2500ml	160	50x20x34" (126x51x86cm)
16-GW2000CT	Basin, Guidewire, 2500ml, ECO ² ™	240	50x20x34" (126x51x86cm)
15-2000	Basin, Guidewire, 2500ml	160	40x20x34" (102x51x86cm)
15-9250	Lid, Basin, Guidewire, 2500ml	120	21x11x18" (53x27x45cm)

Materials

- Polypropylene

Product Attributes

- Graduated in ml, cc and oz for ease of measurement
- Optional lid available
- 16-GW2000CT design features improved nesting and lighter material for more efficient shipping

Sterilization

Non-Sterile: If a product is delivered non-sterile and is ultimately for use in sterile environments, it is intended to be sterilized by the re-packer. This includes further packaging and sterilization according to the validated processes of the re-packer. These products are to be sterilized by ethylene oxide (EO). Other methods of sterilization have not been validated by Alleset.

Shelf Life

Non-Sterile: Established at 5 years based upon sterile packaged product aging studies and normal warehouse storage conditions. After 5 years, the product should be performance tested to ensure compliance to specifications.

Product Certifications/Standards

- CE certified as Class I, according to MDR 2017/745 Annex VIII, Rule 2

Manufacturing Certifications/Registrations

- EN ISO 13485:2016
- Medical Device Single Audit Process Certified

Storage

- General warehouse conditions

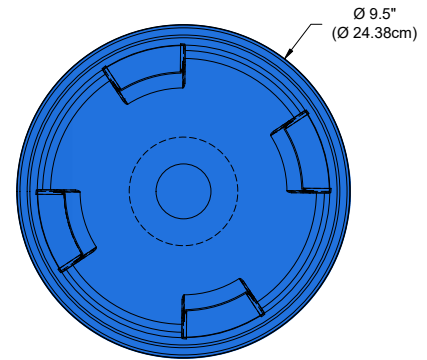

Bowl

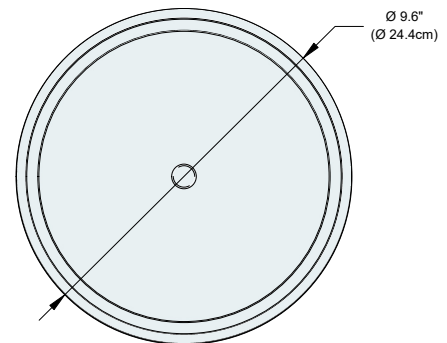

Lid



Alleset
4142 Industry Way
Flowery Branch, GA 30542,
USA
www.alleset.com
SM-TDS-003 2023
Country of Origin Abbreviations per ISO 3166-1, Alpha-2 Codes.

GRI Medical & Electronic Technology Co., LTD
1805 Honggao Road,
314031 Jiaxing, Zhejiang
PEOPLE'S REPUBLIC OF CHINA
www.alleset.com
US FDA Establishment Registration #3004911384

Emergo Europe B.V.
Westervoortsedijk 60,
6827 AT Arnhem,
The Netherlands
www.emergobyul.com

